

N°	CODE
1	HD006000
2	HD018000
3	HD021000
4	HD026055 (4 Unit)
5	HD031010 (4 Unit)
6	HD031055 (4 Unit)
7	HD036000
8	HD021100
9	HD041000
10	HD021035
11	HD046005
12	HD031075
13	HD051005 (0.33 CV)
13	HD051010 (0.50 CV)
13	HD051015 (0.75 CV)
13	HD051025 (1 CV)
13	HD051035 (1.5 CV)
14	HD021060
15	HD056005
16	HD061000 (0.33/0.50 CV)
16	HD061005 (0.75/1/1.5 CV)

N°	CODE
17	HD066000
18	HD071005 (0.33 / 0.50 CV)
18	HD071000 (0.75 / 1 / 1.5 CV)
19	HD071000 (2 Unit)
20	MT006025 (0.33 / 0.50 CV)
20	MT006050 (0.75 / 1 / 1.5 CV)
21	MT028000 (2 Unit)
24	MT076000
25	MT076005
26	MT081000 (1-PH)
26	MT081020 (3-PH)
27	MT076010 (1-PH)
27	MT076015 (3-PH)
28	MT088000 (1-PH)
28	MT088005 (3-PH)
29	MT091000 (0.33 / 0.50 CV 1-PH)
29	MT091010 (0.75 / 1 / 1.5 CV 1-PH)
30	MT096000
31	MT016025 (0.33 / 0.50 CV)
31	MT016040 (0.75 / 1 / 1.5 CV)

N°	CODE
32	MT101015 (0.33 / 0.50 CV (4 Unit))
32	MT101040 (0.75 / 1 / 1.5 CV (4 Unit))
33	MT086040 (0.33 / 0.50 CV)
33	MT086045 (0.75 / 1 / 1.5 CV)
34	MT086050 (0.33 / 0.50 CV)
34	MT086051 (0.75 / 1 / 1.5 CV)
35	MT086055 (0.33 / 0.50 CV)
35	MT086060 (0.75 / 1 / 1.5 CV)
36	HD076010 (2 Unit)
37	HD021115 (2 Unit)
38	HD076005 (2 Unit)
39	HD076000
40	MT999000 (0.33 CV 1-PH)
40	MT999005 (0.50 CV 1-PH)
40	MT999010 (0.75 CV 1-PH)
40	MT999015 (0.75 CV 3-PH)
40	MT999020 (1 CV 1-PH)
40	MT999025 (1 CV 3-PH)
40	MT999030 (1.5 CV 1-PH)
40	MT999035 (1.5 CV 3-PH)

We reserve the right to change all or part of the articles or contents of this document, without prior notice.

Nous nous réservons le droit de modifier totalement ou en partie les caractéristiques de nos articles ou le contenu de ce document sans préavis.

Nos reservamos el derecho de cambiar total o parcialmente las características de nuestros artículos o contenido de este documento sin previo aviso.

Ci riserviamo il diritto di cambiare totalmente o parzialmente le caratteristiche tecniche dei nostri prodotti ed il contenuto di questo documento senza nessun preavviso.

Wir behalten uns das recht vor, die merkmale unserer produkte und den inhalt dieser beschreibung ohne vorherige ankündigung ganz oder teilweise zu ändern.

Reservamo-nos no direito de alterar, total ou parcialmente características dos nossos artigos ou conteúdo deste documento sem aviso prévio.

CJ021035

Carme Fusté Caixàs, Managing Director of Industrias Mecánicas Lago S.A.U.



INDUSTRIAS MECÁNICAS LAGO S.A.U.
Pol. Ind. La Rasa - C/ Muntanya, s/n
17481 Sant Julià de Ramis (Girona) Spain
Tel. +34 972 17 00 58 - Fax +34 972 17 23 63
www.imlago.com

EVIDENCE OF CONFORMITY / DÉCLARATION DE CONFORMITÉ / DECLARACIÓN DE CONFORMIDAD / DICHIARAZIONE DI CONFORMITÀ / KONFORMITÄTSEKRLÄRUNG / DECLARAÇÃO DE CONFORMIDADE

- Declares under their own responsibility that all the pumps: **AMÉRICA**
Manufactured since 20/04/2011, independent of the serial number, are in compliance with:

- o 2006/42/CE Machine directive safety prescriptions.
- o 2004/108/CE Electromagnetic compatibility directive.
- o 2006/95/CE Low voltage Directive.

- Déclare sous sa seule responsabilité que toutes les pompes modèle: **AMÉRICA**
Fabriquées a partir du 20/04/2011, indépendamment du numéro de série, sont conformes avec:

- o Directive de sécurité de machines 2006/42/CE.
- o Directive de compatibilité électromagnétique 2004/108/CE.
- o Directive d'équipes de basse tension 2006/95/CE.

- Declara bajo su única responsabilidad que todas las bombas del tipo: **AMÉRICA**
Fabricadas a partir del 20/04/2011, independientemente del número de serie, son conformes con:

- o Directiva de seguridad de máquinas 2006/42/CE.
- o Directiva de compatibilidad electromagnética 2004/108/CE.
- o Directiva de equipos de baja tensión 2006/95/CE.

- Dichiaro sotto la sua diretta responsabilità che tutte le pompe del tipo: **AMÉRICA**
Prodotte a partire dal 20/04/2011, indipendentemente dal numero di serie, sono conformi a:

- o Direttiva sulla sicurezza delle macchine 2006/42/CE.
- o Direttiva sulla compatibilità elettromagnetica 2004/108/CE.
- o Direttiva apparecchiatura in bassa tensione 2006/95/CE.

- Bescheinigt in alleiniger verantwortung, dass alle Pumpen des typs: **AMÉRICA**
Ab 20/04/2011, produziert wurden, unabhängig von der seriennummer, konform sind mit:

- o Richtlinie 2006/42/CE über die sicherheit von maschinen.
- o Richtlinie 2004/108/CE über elektromagnetische verträglichkeit.
- o Richtlinie 2006/95/CE über die sicherheit von electrischen betriebsmitteln (Niederspannungsrichtlinie).

- Declara sob sua única responsabilidade que todas as bombas do tipo: **AMÉRICA**
Produzidas a partir de 20/04/2011, independentemente do número de série, são conformes com:

- o Directiva de segurança de máquinas 2006/42/CE.
- o Directiva de compatibilidade electromagnética 2004/108/CE.
- o Directiva de equipamentos de baixa tenção 2006/95/CE.

Signed the present conformity evidence / Signe la présente déclaration / Firma la presente declaración / Firma la seguente dichiarazione / Unterzeichnet diese erklärung / Assina a presente declaração:

Sant Julià de Ramis, 20/04/2011

Signature / Firma / Unterschrift / Assinatura

SELF-PRIMMING PUMPS FOR SWIMMING-POOLS
POMPES AUTO-AMORÇANTES POUR PISCINES
BOMBAS AUTOASPIRANTES PARA PISCINAS
POMPA AUTOADESCANTI PER PISCINAS
SELBSTANSAUGENDE PUMPEN FÜR SCHWIMMBECKEN

SA



INSTALLATION AND MAINTENANCE, TECHNICAL DATA
MANUEL D'INSTALLATION ET D'ENTRETIEN, DONNÉES TECHNIQUES
MANUAL DE INSTALACIÓN Y MANTENIMIENTO, DATOS TÉCNICOS
MANUALE DI INSTALLAZIONE E MANUTENZIONE, DATI TECNICI
HINWEISE FÜR EINBAU UND WARTUNG, TECHNISCHE DATEN

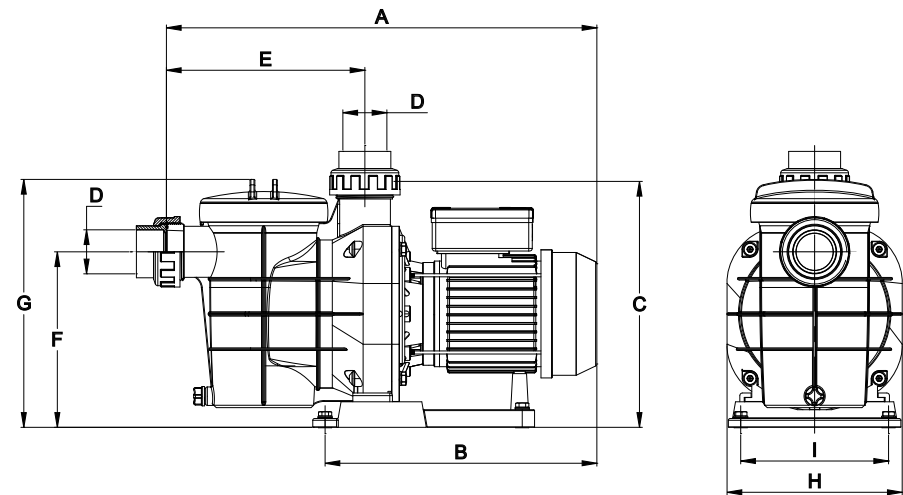

ELECTRICAL CONNECTIONS - BRANCHEMENTS ÉLECTRIQUES
 CONEXIONES ELÉCTRICAS - COLLEGAMENTI ELETTRICI
 ELEKTRISCHE ANSCHLÜSSE - CONEXÕES ELÉTRICAS

SINGLE PHASE MOTORS - MOTEURS MONOPHASÉS - MOTORES MONOFÁSICOS
 MOTORI MONOFASE - EINPHASENMOTOREN - MOTORES MONOFÁSICOS

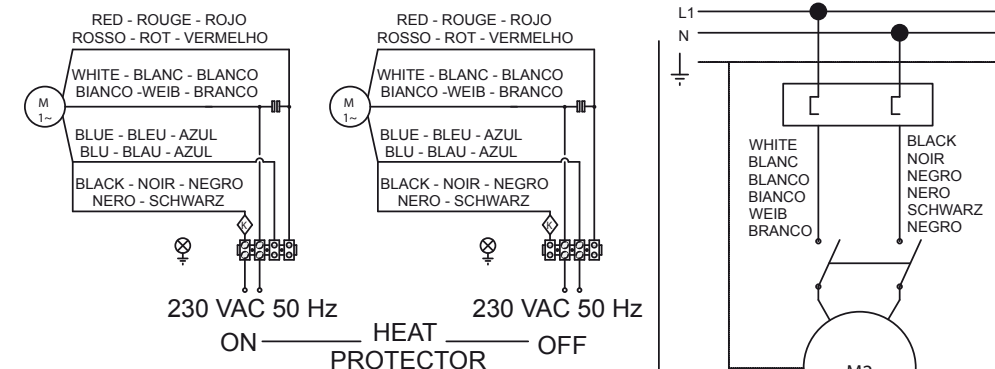

THREE PHASE MOTORS - MOTEURS TRIPHASÉS - MOTORES TRIFÁSICOS
 MOTORI TRIFASE - DREINPHASIGE MOTOREN - MOTORES TRIFÁSICOS

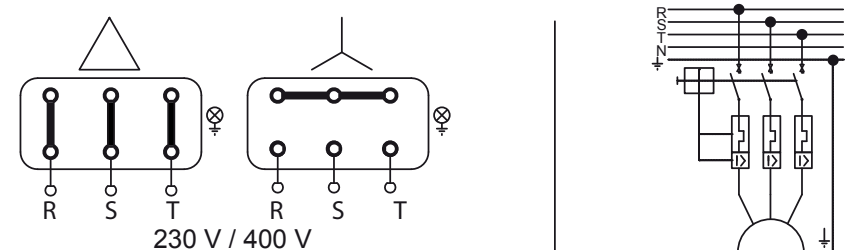

Code	Voltage	Intensity Relay Regulation
SA033M	230 V	2,9 A
SA050M	230 V	3,8 A
SA075M	230 V	4,0 A
SA075T	230/400 V	2,4 / 1,6 A
SA100M	230 V	6,2 A
SA100T	230/400 V	4,7 / 2,7 A
SA125M	230 V	7,6 A
SA125T	230/400 V	6,1 / 3,5 A

67 dBA	73 dBA	78 dBA	
SA033M	SA050M	SA075M	SA100M
		SA075T	SA100T
			SA125M
			SA125T

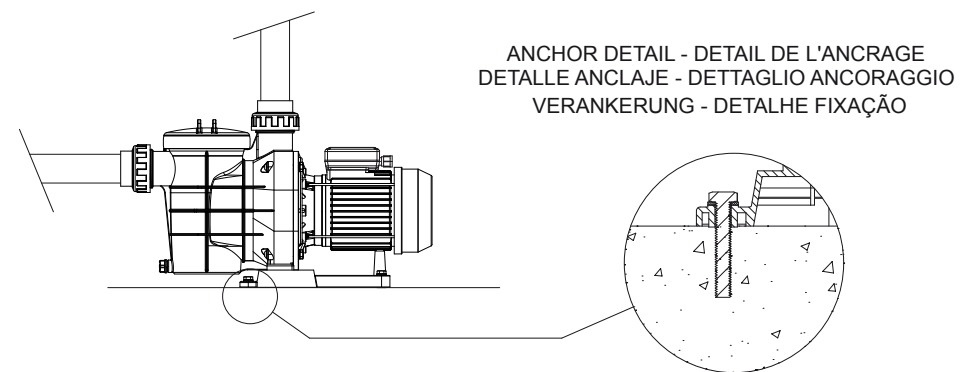

Fig. 1

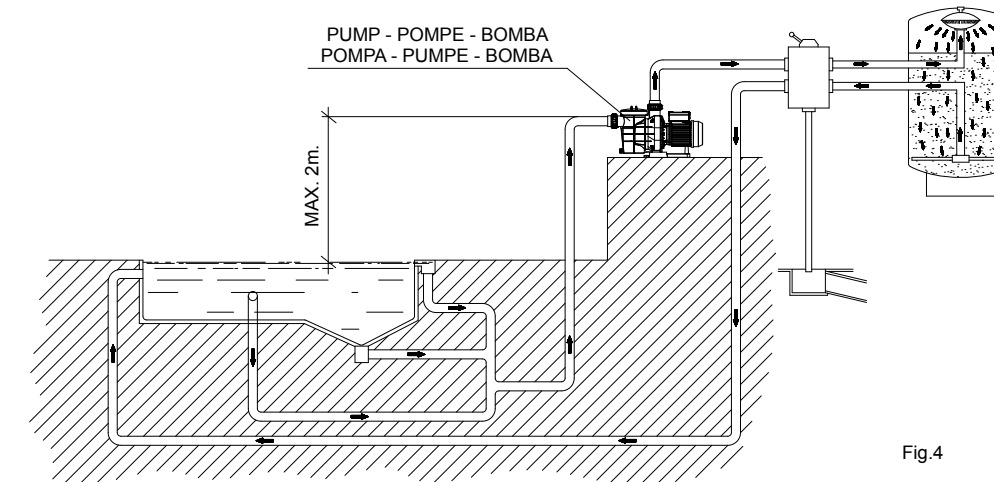
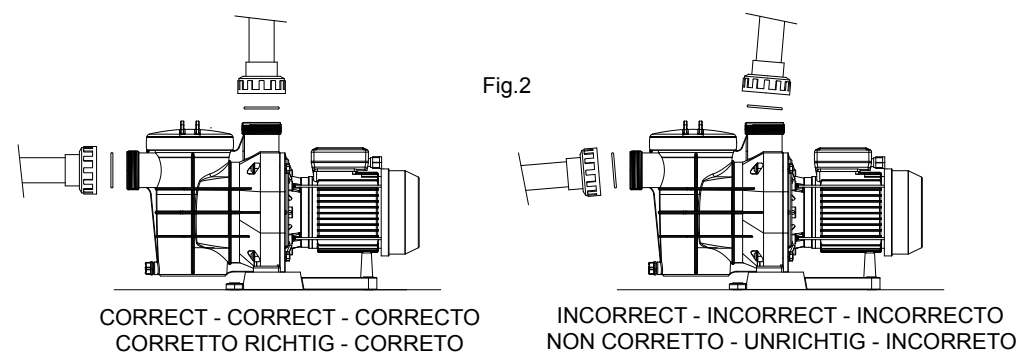

Fig. 4

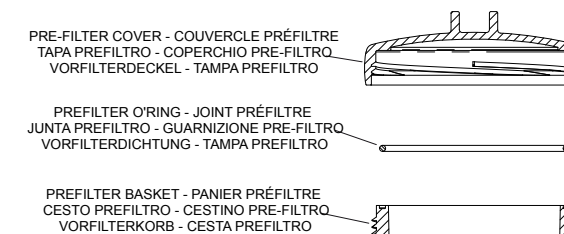

Fig. 5

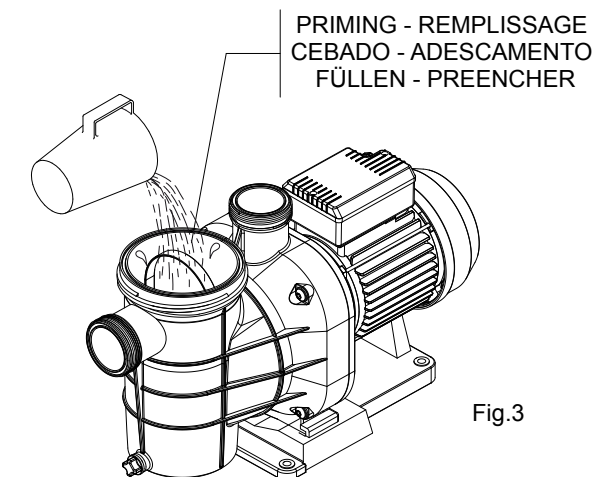
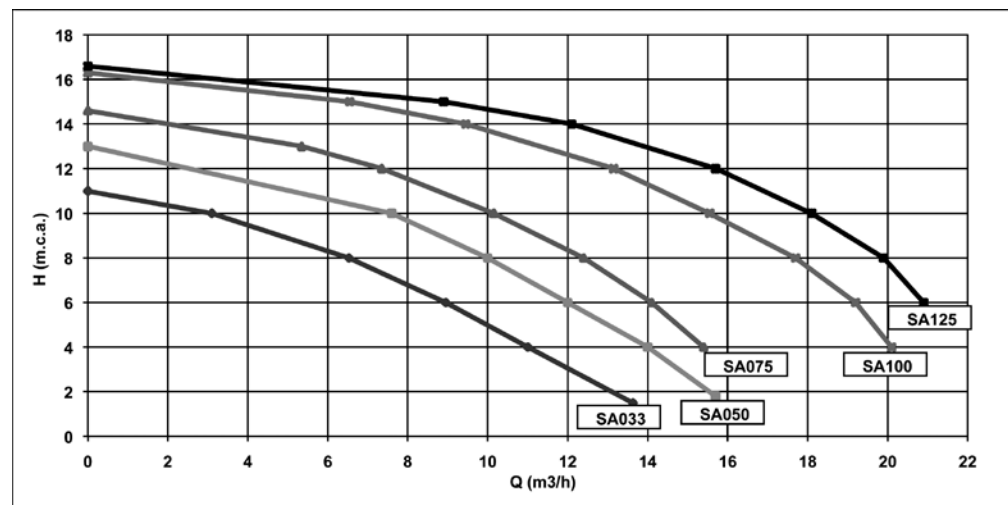

Fig. 3

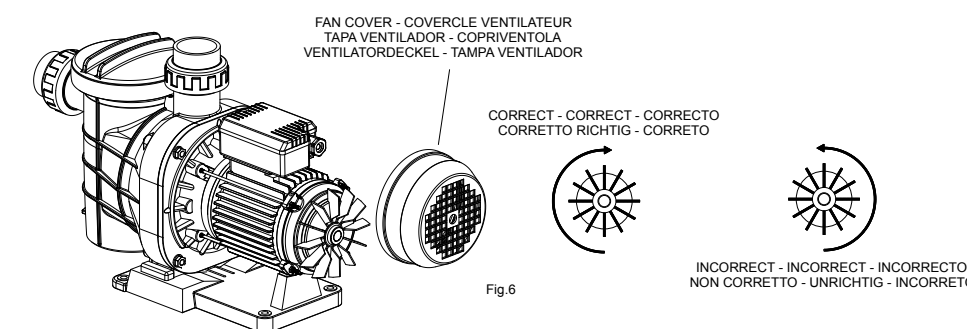

Fig. 6